



# Structural Mods - Classification, Requirements and Cert. aspects

FAA Workshop, Wichita, July 19<sup>th</sup> – 20<sup>th</sup>, 2016

# Introduction

## Contents

- Type design data definition and the need to control changes after issue of the TC.
- Examples of changes to Materials and Process specifications.
- Classification of changes to the design data (drawings or models).
- Major insignificant change examples, horizontal stab 55 lbs weight reduction.
- Some thoughts on MRB.
- Development of thermoplastic structures at Fokker.

## Type design data definition (1/2)

Extract from EASA PART 21 Subpart G GM 21A.131

*Applicable design data is defined as all necessary drawings, **specifications** and other technical information provided by the ... holder of ... TC ... and released in a controlled manner to a production organization approval holder. This should be sufficient for the development of production data to enable repeatable manufacture to take place in conformity with the design data.*

*Prior to issue of the TC ... design data is defined as 'not approved' but parts and appliances may be released with an EASA Form 1 as a certificate of conformity.*

*After issue of the TC ... this design data is defined as 'approved' and items manufactured in conformity are eligible for release on an EASA Form 1 for airworthiness purposes.*

- > Note type design data should reside at the OEM and has to be released in a controlled manner to the production organization.
- > Note also (Material and Process) **specifications** are part of the type design data, strength and failure modes of components involving heat treatment, (metal) bonding and / or composites depends heavily on process windows / pretreatment etc.

-> **How do we deal with changes after issue of the TC / structural mods?**

## Type design data definition (2/2)

From the proposed EASA Monocoque Sandwich Structure Certification Memo

*Recognizing that several structural failures have resulted from various combinations of design, production, and continued airworthiness deficiencies, the applicant must clearly demonstrate that the structure has been subjected to the appropriate coordinated involvement of material suppliers, the design organization (TC Holder), production organizations, and those with appropriate continued airworthiness experience throughout the supply, design, development, and certification processes.*

*The intent of such a coordinated effort should be the early identification of hazards and the assessment of potential risks relative to the recognized criticalities and design complexities, the manufacturing process, the envisaged production supply chain and environment, particularly with respect to continued airworthiness implications. Appropriate actions should then be developed and documented for risk mitigation, including the necessary organizational policies and procedures in order to ensure the integrity, efficiency and effectiveness of the action taken in addition to **appropriately managing changes when occurring to the approved design and production.***

-> **How do we appropriately manage changes?**

# Examples of changes to M&P specifications (1/5)

## Introduction

- M&P specifications specify or control o.a.:
  - Individual Product Specifications (IPS) or so-called procurement specs
  - Batch acceptance values and batch release values
  - Storage requirements and shelf life
  - Clean room requirements
  - Processing windows and process control test requirements
  - Inspection requirements, visual and e.g. attenuation levels for NDI
  
- Together these are of utmost importance to control the strength (allowables) and critical failure modes of the products manufactured.
  
- Approvals of M&P specifications are generally within the OEM M&P departments with some exceptions:
  - Some critical M&P specs might not be delegated and require FAA approval by the ACO, at least for the initial release prior to TC.
  - Some approvals might be delegated to the tier-1 aerostructures supplier, in close cooperation with the OEM (respecting type design data requirements see slide 3).

## Examples of changes to M&P specifications (2/5)

### Changes

- Drawing or model changes are generally governed by a PCMT (Production Change Management Team) or CCB (Configuration Control Board) involving multiple functions and stringent rules for controlling effectivity of the change.
- For M&P specs, frequently there is a need to make changes as well:
  - Obsolescence issues in the supply chain
  - Changes for environmental or safety / health reasons, solvents, chromates
  - Potential for cost reductions
  - New products added to the portfolio requiring slight changes to process windows
- Generally these M&P specs updates are achieved by raising the issue of the spec, without controlling effectivity (issue date + 30 days might be the standard window to implement the change in production). This is to avoid the cost of drawing or model updates in case a new M&P spec call-out would be used.
- It is essential to verify for all products using the applicable spec, that there is no adverse effect of the change on strength or failure modes, in consultation with structures.

## Examples of changes to M&P specifications (3/5)

### Change of Composite Material and/or Process

- AMJ 25.603 in Europe and later AC20-107B Appendix 3 provided guidance in case of a change in composite material and/or process:
  - Case A: A change in one or both of the basic constituents, resin, or fiber (including sizing or surface treatment alone) would yield an alternate material. Other changes that result in an alternate material include changes in fabric weave style, fiber areal weight, and resin content.
  - Case B: Same basic constituents, but any change of the resin impregnation method. Such changes include: (i) prepregging process (e.g., solvent bath to hot melt coating), (ii) tow size (3k, 6k, 12k) for tape material forms with the same fiber areal weight, (iii) prepregging machine at the same suppliers, (iv) supplier change for a same material (licensed supplier).
  - Case C: Same material, but modification of the processing route (if the modification to the processing route governs eventual composite mechanical properties). Example process changes of significance include: (i) curing cycle, (ii) bond surface preparation, (iii) changes in the resin transfer molding process used in fabricating parts from dry fiber forms, (iv) tooling, (v) lay-up method, (vi) environmental parameters of the material lay-up room, and (vii) major assembly procedures.
- Case B (and sometimes C): 'replica structure'. Case A (and sometimes C): 'new structure'.

## Examples of changes to M&P specifications (4/5)

### Change of Composite Material and/or Process

- For Case A, for example if there is a wish to use 2 material suppliers, it is possible to have only 1 material spec call-out for both, but separate procurement specs and batch acceptance / batch release values are required to control both suppliers sufficiently tight. Full 5 batch material allowables have to be developed for both. Most critical allowables should be used for cert. analysis. Sufficient higher level testing is needed for both (at least panel level). F/DT (no growth) substantiation is required for both.
- In general, for Case A, if the 2 alternate material suppliers have not been developed in parallel during the initial TC effort, it is not possible to add the second source later without changing the material spec call-out on the type design data -> a new material spec call-out, drawing or model change and PoE will have to be generated to sufficiently control the additional cert. effort.
- For Case B, in general, the material spec call-out on the type design data can remain as is. But a 3 batch (TBC) equivalency effort is required to substantiate the change. Fokker example: TH5.XXX/101 and /102 while material spec call-out on dwg is TH5.XXX/1.
- For Case C, sufficient testing is required **to verify for all products using the applicable spec, that there is no adverse effect of the change on strength or failure modes, in consultation with structures. Otherwise, do not raise issue of the process spec, use new call-out.**
- For critical processes like bonding, welding, SPC on process control testing is invaluable.



# Examples of changes to M&P specifications (5/5)

## Change of Composite Material and/or Process

- Example of change in production equipment at fiber manufacturer leading to drop in thermoplastic welding temperature (this had to be compensated by readjusting the magnetic induction field). Discovered by monitoring the process control test data.

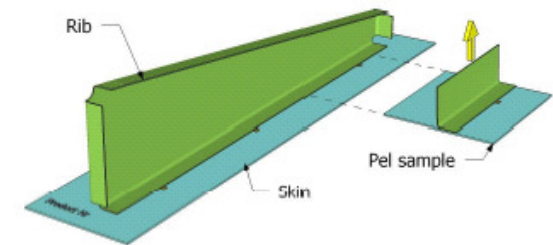
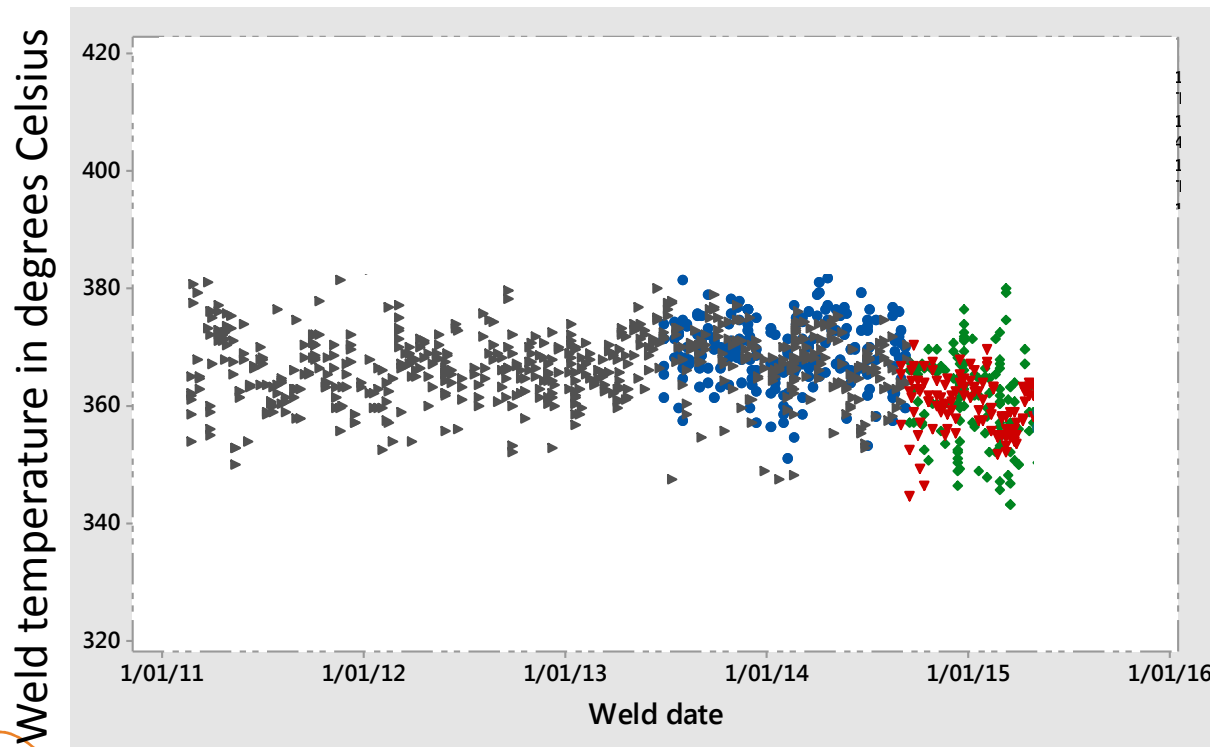

# Classification of changes to drawings or models

CLCCD = Component Level Configuration Control Document

Type of Change	Example ECR's	Cert plan needed?	CLCCD change?	New cert reqs / basis?	TCDS change?
Minor	Alterations (no FFF)	N	N	N	N
Minor	FFF changes	N	N	N	N
Major Insignificant	See examples	Y	Y	N	N
Major Significant	E.g. fuselage stretch	Y	For changed parts only		Y
Substantial	New TC	Y	Y	Y	Y

# Major insignificant change examples (1/4)

## Introduction

- Fokker is currently working 2 – 3 ‘major insignificant’ changes / structural mods for which certification plans have been or will be submitted to the FAA:
  - For initial TC, there is usually insufficient time to fully optimize a composite design, also there is still some inaccuracy in the external loads. Consequently a 3 – 5% weight optimization is often possible after completion of all the initial TC tasks. Fokker is currently working a 55 lbs weight reduction for a horizontal stab. Cert. plan FAA approved.
  - For chromate reduction reasons (European legislative requirements ‘REACH’), Fokker is in the process of changing from a CAA to a PSA metal bonding pretreatment process. Bond material and failure modes (cohesive failures are allowed only) will remain the same. New process spec call-outs will be used. FAA familiarization meeting held. Cert. plan in sign-off.
  - For a TBD application, allowables will be generated for a new thermoplastic material carbon/PEKK. Advanced Design Development cert. plan in sign-off.

## Major insignificant change examples (2/4)

### Horizontal stab 55 lbs weight reduction

- External loads and flutter margins revalidated with OEM due to changed mass / stiffness distribution. Some new loadcases defined, flutter margins improved.
- Foam cores of stringers replaced by lower density material, cut-ups and adhesion tests performed prior to selection.
- Initial TC design featured relatively heavy stringers and buckling allowed up to 10 plies skin only -> high stringer pop-off margins, RTD panel tests only.
- New design more optimized, lighter stringers, buckling allowed up to 13 plies skin, more critical pop-off margins, RTD and HTW panel tests performed.
- Elaborate revalidation of no-growth based on conservatism in 2010 full-scale component test / spectrum.

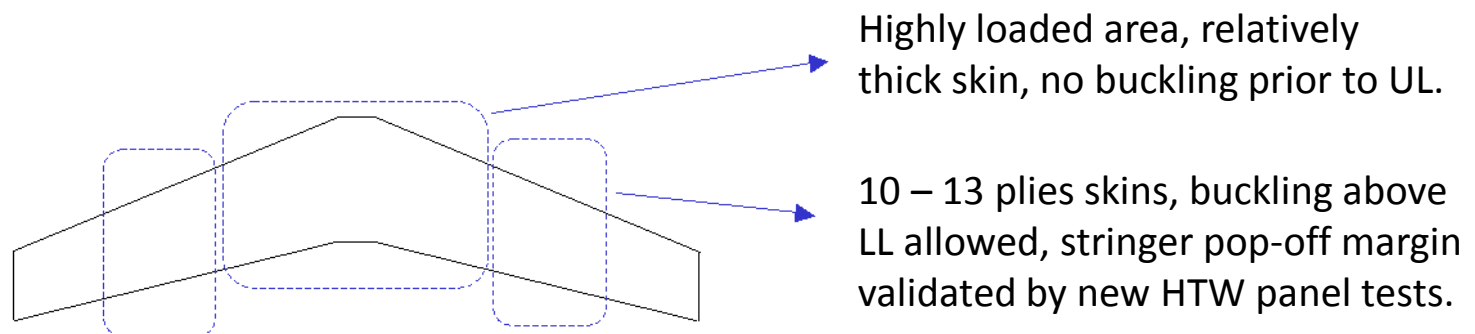

# Major insignificant change examples (3/4)

## 23B – non weight saved Upper skin, Minimum Min. Principal, Limit Load

- Enveloped min. principal strains of upper skin @ LL
- Fine grid 23B FEM (incl. access covers), applicable to A/C 6007-6315
- All (37) loadcases considered, selected in GF-10-0115
- L2R1 loads

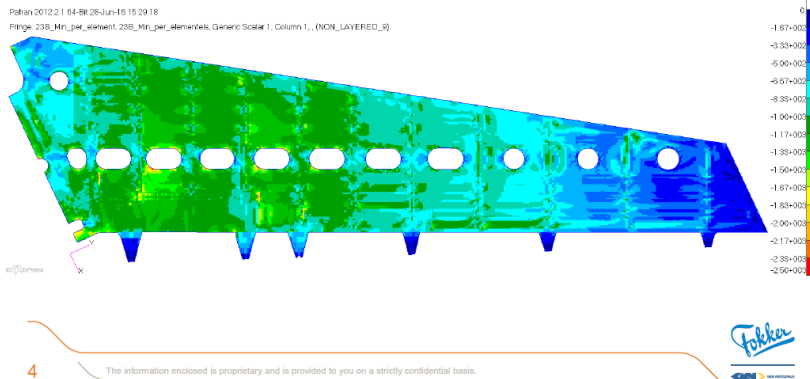

## 25D –weight saved Upper skin, Minimum Min. Principal, Limit Load

- Enveloped min. principal strains of upper skin @ LL
- Fine grid 25D FEM (incl. access covers), applicable to A/C 6316-sub.
- All (47) loadcases considered, selected in GF-10-0115
- L3R5 loads

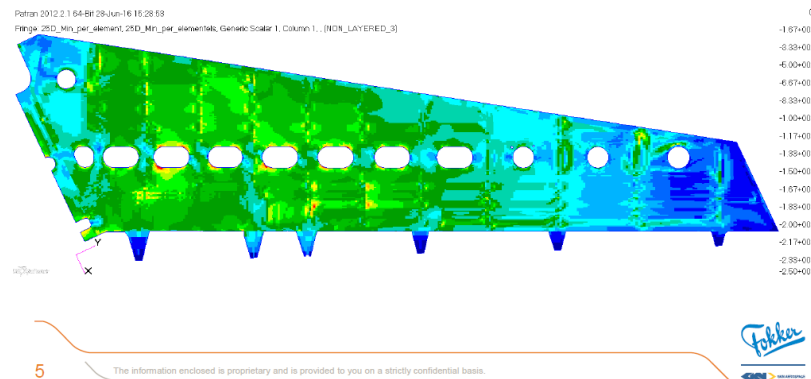

## 23B – non weight saved Lower skin, Minimum Min. Principal, Limit Load

- Enveloped min. principal strains of lower skin @ LL
- Fine grid 23B FEM (incl. access covers), applicable to A/C 6007-6315
- All (37) loadcases considered, selected in GF-10-0115
- L2R1 loads

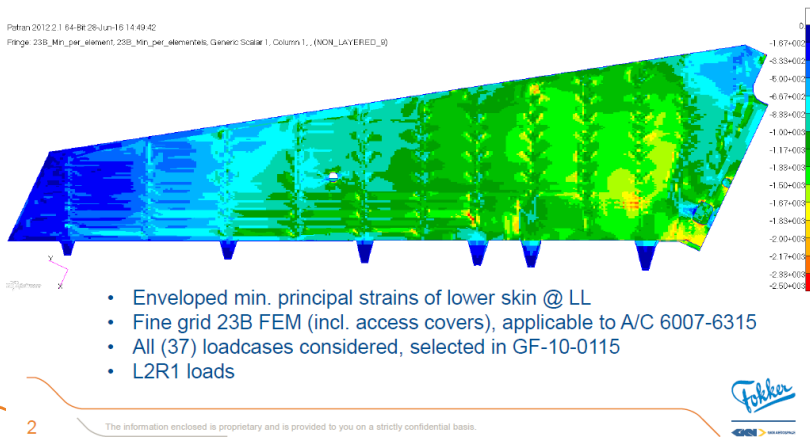

## 25D –weight saved Lower skin, Minimum Min. Principal, Limit Load

- Enveloped min. principal strains of lower skin @ LL
- Fine grid 25D FEM (incl. access covers), applicable to A/C 6316-sub.
- All (47) loadcases considered, selected in GF-10-0115
- L3R5 loads

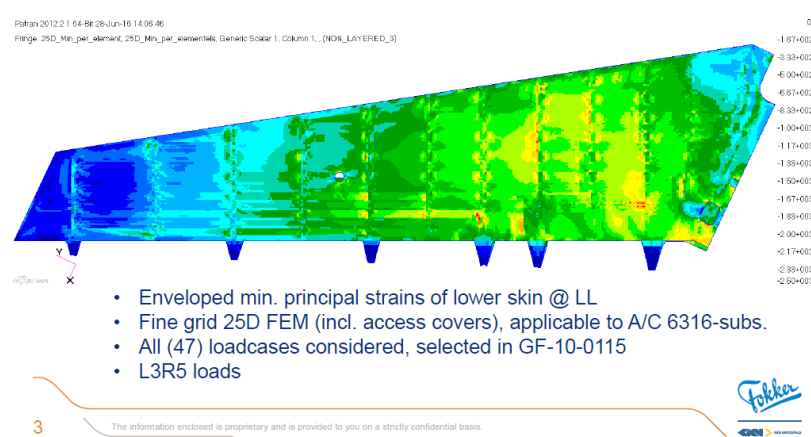

# Major insignificant change examples (4/4)

RTD and HTW panel tests, now at 13 plies thickness

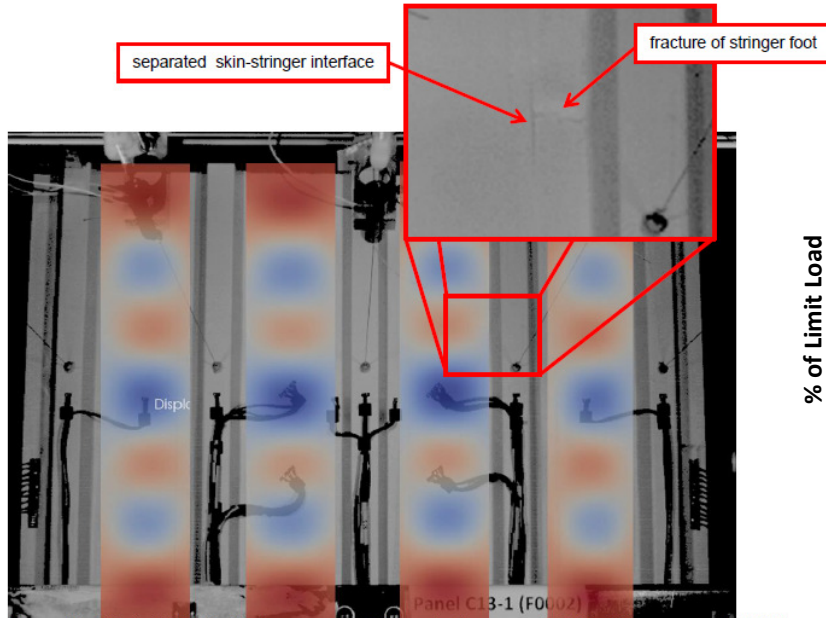
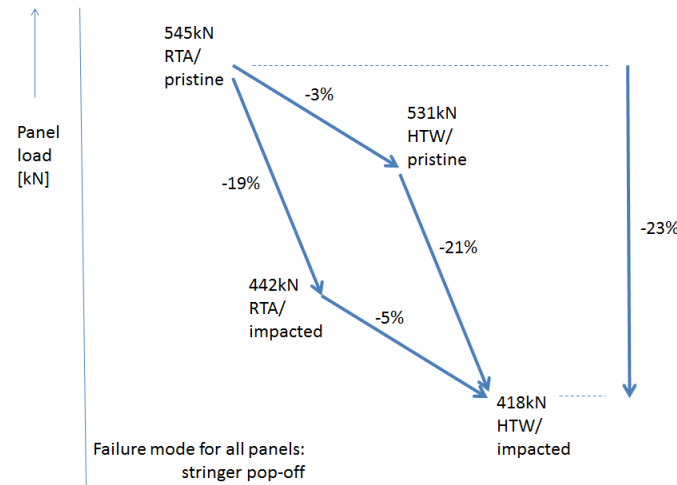
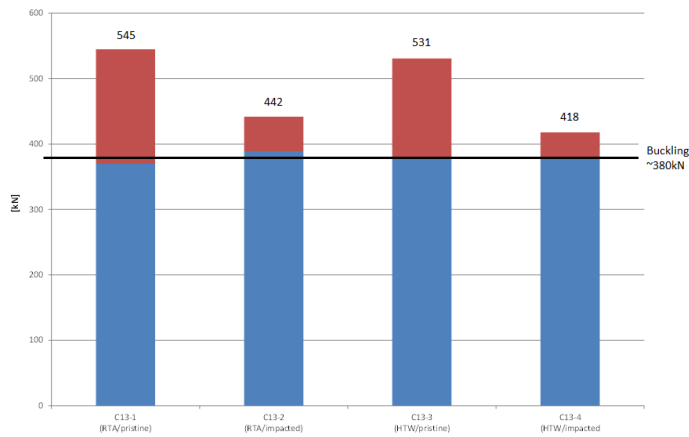
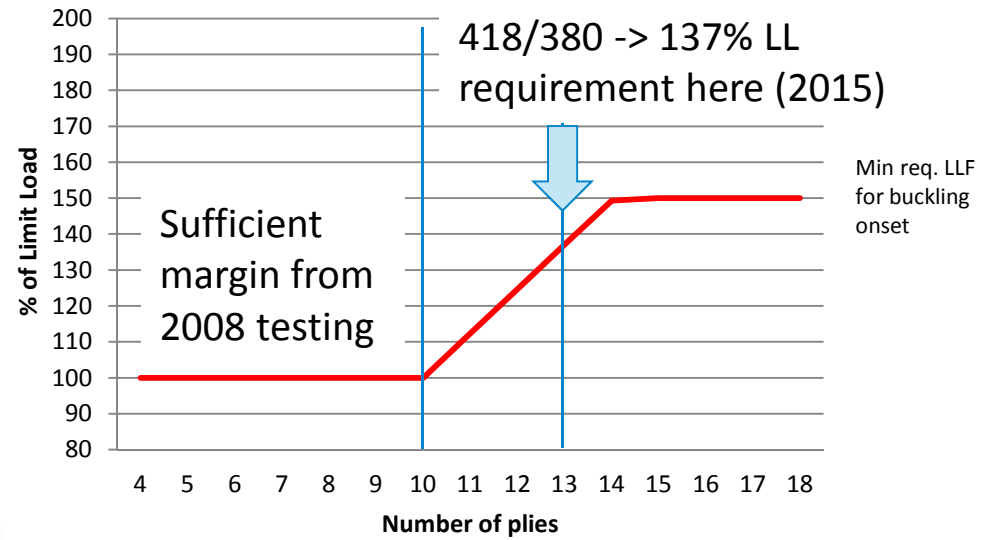

Figure 5: C13-1 ARAMIS displacement at failure (red = towards OML, blue = towards IML)

## buckling stability requirement



## Some thoughts on MRB

- In principle, MRB is approving 'small' changes to the baseline type design i.e. structural mods. Make sure all static and F/DT aspects are considered and that no new failure modes are introduced.
- Damaged stringers repair example below resulted in 5 lbs overweight structure.
- Effect of 'second cure' and wet-lay up repair on stringer pop-off failure mode has to be understood and validated.
- In service repairs are even more challenging due to difficulty to get a good surface preparation and the variability in repair materials and processes.
- CMH-17 SoBR WG is providing some excellent guidelines.

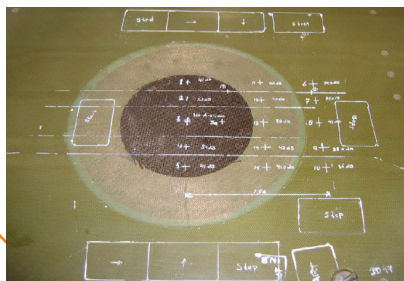

# Development of Thermoplastic Structures at Fokker (1/9)

## Overview

- Fokker has taken a step-by-step approach 1990 – 2015:
- Starting with ice protection plates / landing gear doors,
- via control surface ribs, cabin pressure floor structure\*, and fixed wing leading edges (not PSE but failure could compromise continued safe flight or landing).
- to complete elevators and rudders, and now stabilizers.

\*Approx. 20,000 pressure boards produced to date.





# Development of Thermoplastic Structures at Fokker (2/9)

Transition from secondary to primary structure applications

Category		Failure has no airworthiness consequences, economic impact only	Continued safe flight or landing not compromised, consider size of released elements	Failure could compromise continued safe flight or landing, impacts PSE's.	PSE, failure could result in catastrophic failure of aircraft
2010	Carbon /PEKK				TAPAS thermoplastic stabilizer demonstrator
2005	Carbon /PPS		F50 MUC door, A340-500/600 access panels	G650 elevator and rudder parts	
2000	Glass /PPS		A340-500/600 fixed leading edge J-nose	A380-800 J-nose	
1995	Carbon/PEI	G550 non-pressure floor	G550 rudder trailing edge	G550 rudder ribs, pressure floor	
1990	Glass/PEI	Ice Protection Plates F50, Floor Panels F70/F100			

nonstructural / secondary



structural / primary

# Development of Thermoplastic Structures at Fokker (3/9)

Airbus 'J-Noses' resistance welding

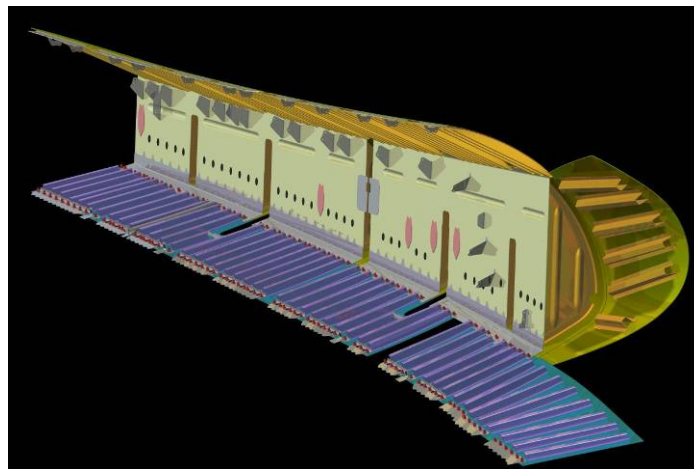
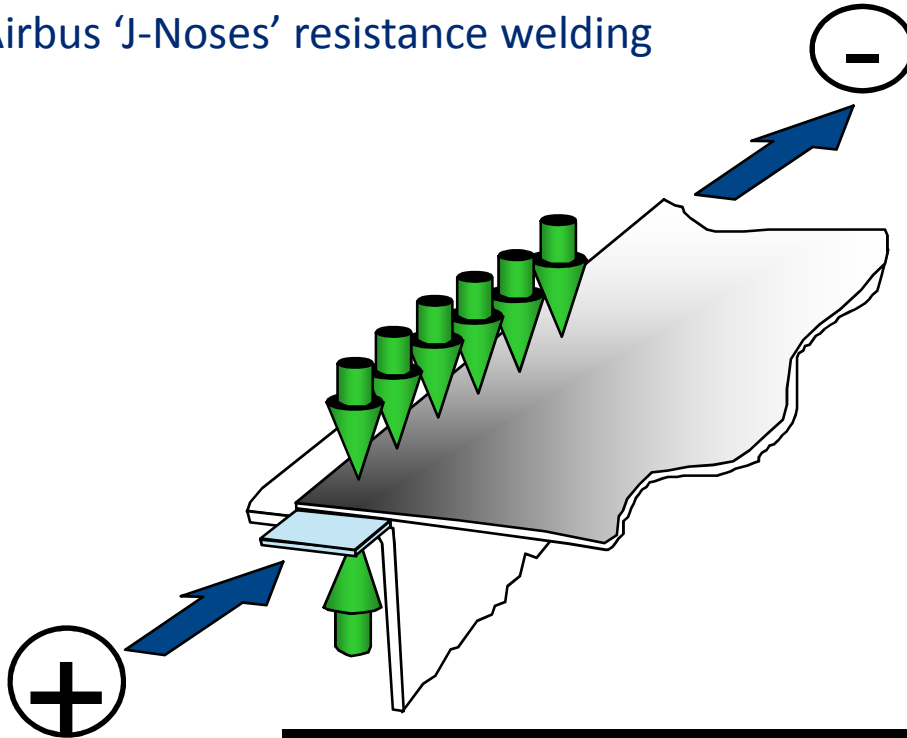

# Development of Thermoplastic Structures at Fokker (4/9)

Repairs...



# Development of Thermoplastic Structures at Fokker (5/9)

## Gulfstream Elevators and Rudder



# Development of Thermoplastic Structures at Fokker (6/9)

## Historical overview of rudder design

### Gulfstream III

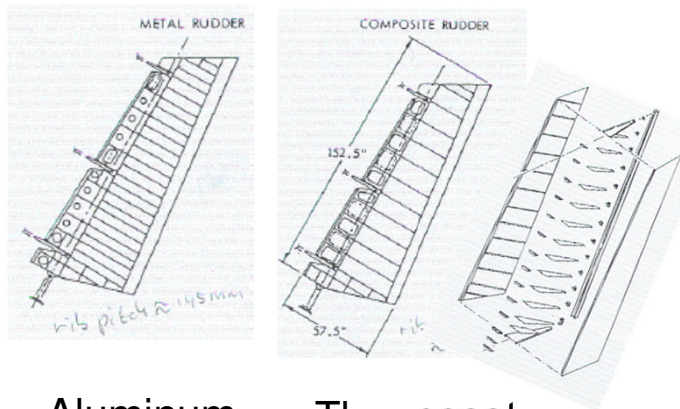

- Aluminum rudder
- Thermoset monolithic design
- High parts count, complex assembly

Lockheed Georgia Co design 1984

### Gulfstream IV, V

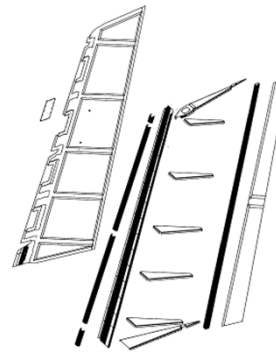

- Thermoset sandwich skin design
- Lower parts count, lower cost
- Equivalent weight
- 1200+ in service

Fokker design 1997

### Gulfstream G650

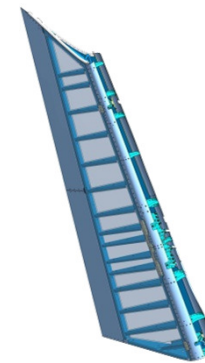

- Thermoplastic monolithic design
- Thermoplastic processes, 20% lower cost, 10% lower weight
- 180+ in service

Fokker design 2010

70,000 FH recently completed.

# Development of Thermoplastic Structures at Fokker (7/9)

Carbon/PEKK new developments



Unconventional laminates in center area (fiber steering) require new test – analysis approach to cover all variables.

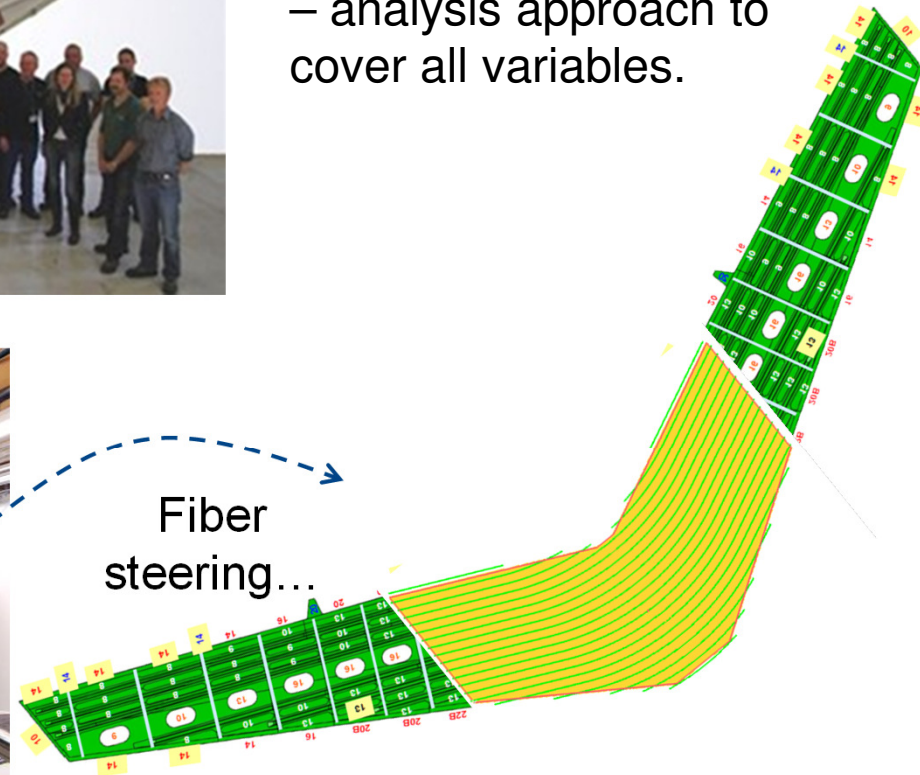
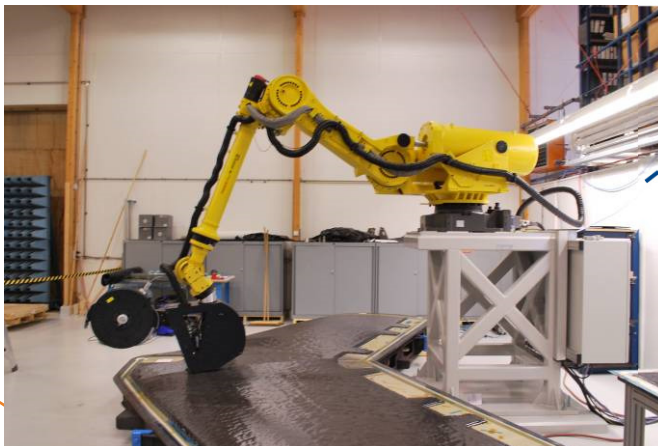

# Development of Thermoplastic Structures at Fokker (8/9)

Carbon/PEKK new developments



Repetition of full-scale stab test but up to 240% LL with the thermoplastic lower skin, 20" tip deflection compared to 12" in the original test.

# Development of Thermoplastic Structures at Fokker (9/9)

Carbon/PEKK new developments



Postbuckling behavior of skin panels



# Questions?



Thanks for your attention!